

TAC ATTACK

Tac Attack April 1985

APRIL 1985

Office	Info	Action	Initial
SE			
SEF			
SEG			
SEW			

[Handwritten signature]



Handling aircraft emergencies

ANGLE OF ATTACK

Angle of Attack



**CITATION
TO ACCOMPANY THE AWARD OF
THE SECRETARY OF THE AIR FORCE SAFETY AWARD**

The Secretary of the Air Force Safety Award for 1984 is presented to the Tactical Air Command for outstanding achievements in mishap prevention.

Tactical Air Command's safety program management reflected strong command support, supervisory involvement, and professional adherence to safe operational procedures and standards, and was highly effective. The command achieved the fewest number of Class A aircraft mishaps and lowest mishap rate in the past 10 years and sustained a downward rate trend for the sixth consecutive year. Class B aircraft mishaps were also lower than the previous year. These achievements, compiled while flying more than 707,000 hours performing realistic combat training missions in 18 different types of high-performance aircraft, testify to the highest degree of professionalism among pilots, aircrew, and support personnel. Accomplishments in ground safety were equally impressive. The fewest number of ground mishap fatalities in Tactical Air Command's history were experienced in 1984. The number of fatalities was more than 40 percent lower than the previous year, and military injuries were more than 20 percent lower. Additionally, explosives mishaps were more than 35 percent lower than the previous year.

The achievements of the Tactical Air Command exemplify the high standards established for the Secretary of the Air Force Safety Award and reflect great credit upon the command and the United States Air Force.

Verne Orr
Secretary of the Air Force



HON VERNE ORR
SECRETARY OF THE
AIR FORCE

GEN JEROME F.
O'MALLEY
COMMANDER



COL HAL WATSON
CHIEF OF SAFETY

MAJ LEW WITT
EDITOR

MARTY DILLER
WRITER-EDITOR

STAN HARDISON
ART EDITOR

AIC KELVIN
TAYLOR
STAFF ARTIST

General Jerome F. O'Malley 4
 A message from the TAC Commander.

Weapons Words 6
 Working with TAC's weapons systems.

TAC Tips 8
 Interest items, mishaps with morals, for the TAC aircrew member.

F-16 Emergency Situation Training 11
 What'cha gonna do now, Ace?

Don't Zero Out Your Axis 12
 An audit trail of spurious electrons in the electric jet.

USAF Thunderbirds 16
 By Bob Simpson.

Emergency R.O.E. 18
 Sometimes your only recourse is to pull the plug . . .

Chock Talk 20
 Incidents and incidentals with a maintenance slant.

Coping with an Inflight Emergency 23
 Basic lessons from the School of Hard Knocks.

Down to Earth 26
 Items that can affect you and your family here on the ground.

Part Time Flyers 28
 Lack of recent experience may be setting you up for the *big one*.

Letters 30
 Our turn to take flak.

TAC Tally 31
 The flight safety scoreboard.

TACRP 127-1

TAC Attack is not directive in nature. Recommendations are intended to comply with existing directives. Opinions expressed are those of the authors and not necessarily the positions of TAC or USAF. Mishap information does not identify the persons, places or units involved and may not be construed as incriminating under Article 31 of the UCMJ. Photos and artwork are representative and not necessarily of the people or equipment involved.

Contributions are encouraged, as are comments and criticism. We reserve the right to edit all manuscripts for readability and good taste. Write the Editor, *TAC Attack*, HQ TAC/SEP, Langley AFB, VA 23665-5001; or call AUTOVON 432-3658.

Distribution F(X) is controlled by TAC/SEP through the PDO, based on a ratio of 1 copy per 10 persons assigned. DOD units other than USAF have no fixed ratio; requests will be considered individually.

Subscriptions for readers outside DOD are available from the Superintendent of Documents, Government Printing Office, Washington, D.C. 20402. All correspondence on subscription service should be directed to the superintendent, not to TAC/SEP.

TAC Attack (ISSN 0494-3880) is published monthly by HQ TAC/SEP, Langley AFB, VA.

POSTMASTER: Send address changes to *TAC Attack*, TAC/SEP, Langley AFB, VA 23665-5001.

Second-class postage paid at Hampton, Virginia, and additional mailing offices.

The TAC Commander

General Jerome F. O'Malley

During his first six months as the TAC Commander, General Jerome F. O'Malley has visited the majority of TAC bases and has plans to visit all of them in the near future. Throughout his travels around TAC, General O'Malley has had a chance to get to know many of you and listen to your thoughts and concerns about how we are doing business in the command.

Communication being a two-way street, *TAC Attack* recently asked General O'Malley what points he would like to make to you and, in particular, to those of you involved in TAC's daily flying operations. Here's what he had to say:



First, I want to strongly thank and compliment everyone responsible for TAC's excellent flying safety record. Your outstanding efforts resulted in TAC earning the Secretary of the Air Force Safety Award for 1984, and it was a personal honor for me to receive the award on your behalf from Secretary Orr in February. Although no accident rate is desirable, your improvements in flying safety have been magnificent. You're doing many things right, and you're working harder than ever before -- supervisors and new guys alike. The level of concentrated, realistic training in TAC is the highest I have ever seen in my career. I feel that we are better prepared for war right now -- April 1985 -- than we were during World War II, Korea, Vietnam or anytime since Vietnam. The realism is there, and we're getting the flying time needed to reap the benefits of that realism.

Still, with all that we have accomplished, I am very concerned about the increase in command-controlled accidents -- those accidents that were caused or could have been prevented by



people in TAC. This is a subject that I discussed in the January 1985 issue of *TAC Attack*, and it still worries me very much. What really troubles me is that the command-controlled accidents were, by and large, caused by experienced people in relatively non-demanding circumstances. Take, for example, the maintenance crew improperly preparing an F-4 centerline fuel tank for flight. The result -- fire immediately after takeoff and the loss of an aircraft. Then, there was the pilot who tried to go around on one engine with the speedbrakes out and another pilot who shut down the wrong engine. All of these spell *complacency*.

When aircrews fly a demanding RED FLAG mission, all indications are that they plan it well, brief it well, and it's well thought through. However, when performing a routine mission like picking up an airplane and flying it back home, some aircrews are apparently not applying the same degree of thoroughness -- they are not thinking through the simple and are reserving their thinking time for the more complex.

And it isn't the lieutenants who are making the mistakes -- we're supervising the lieutenants pretty well. But, we're not doing well at all with their supervisors. For example, it was a supervisor who shut down the wrong engine.

Admittedly, we are not operating an airline; we are preparing for war. When we do that, we are going to lose aircraft. If realistic training for war were the problem, I would have to give some thought to backing away from it. But considering that over 90% of our 1984 accident rate was command-controlled, training realism is not the problem -- complacency is! We have to turn that around and give the same rigorous, disciplined approach to the mundane, day-in and day-out tasks that we give to the demanding missions.

You proved in 1984 that you can train more realistically and fly safer than ever before, and I compliment you on your efforts. The challenge now is to eliminate those accidents that are within our power to prevent. You are the professionals -- you can do it! ➤

YEAR	AIRCRAFT DESTROYED	TAC ACCIDENT RATE	FIGHTER/ATTACK COMMAND-CONTROLLED* RATE
1981	31	4.9	1.6
1982	30	4.2	1.9
1983	26	3.7	2.5
1984	23	3.2	3.0

*Command-controlled mishaps are those mishaps which are caused or could have been prevented by people in TAC.

WEAPONS WORDS

Cable fable

An A-10 was on a local training mission dropping BDU-33 practice bombs on the nearby range. The aircraft was hauling several triple ejector racks, each loaded with three bombs. On the seventh pass, when the pilot pressed the bomb button to release one bomb from station 9, the TER and the other two practice bombs came

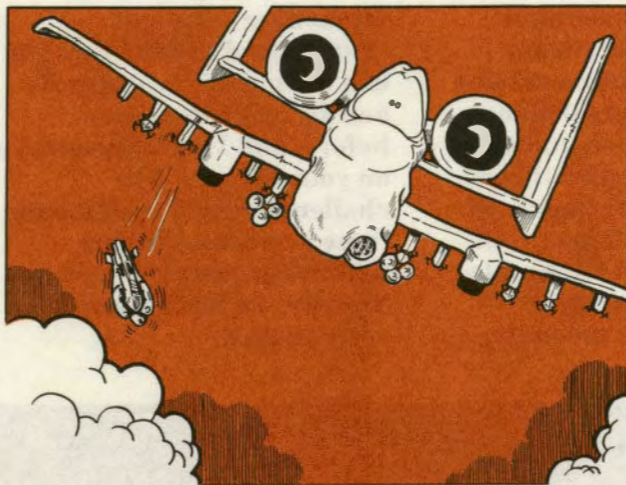

along for the ride too.

Troubleshooters noticed that the release cable was extremely difficult to install properly because of flat spots on the mechanical lock rings. That probably meant that way back before take-off someone had left the connector of the TER-9A's release cable cocked. With the connector at an angle, voltage that was intended to release a single bomb from the TER instead re-

leased a single store from the station, the TER.

Since stubborn and contrary cables can cause trouble for both load crews and pilots, maybe we should keep better track of what shape they're — before they give us a hard time. This unit now numbers their cables and keeps track of them. They inspect release cables every 120 days for ease of installation as well as electrical continuity.

Hand jive

During a routine check of the jettison circuitry of an F-4 Phantom, one worker climbed into the cockpit, another cranked up the power unit and a third stood out in front of the pitot boom to direct the operation. While the comm cord was being connected, the worker out front gave a thumbs up signal to tell the worker in the cockpit *the APU is up to speed*. But the guy in the pilot's seat thought that the thumbs up meant *OK, we're ready down here, go ahead and do the check*; so he set up the cockpit switches and pushed the stores jettison button. Kapow! An empty 600-gallon centerline fuel tank did a high-priced nose-dive into the parking ramp.

When the comm cord was finally plugged in a few seconds later, the guy in front was able to explain to the guy in the cockpit what he really meant by the thumbs up. But it was too late then.



Being late with the verbal communication wasn't the only problem. The aircraft forms and word were trying to tell the crew that the ches were loaded. But they never checked to see if the jettison carts were removed.

This little tale contains a lot of ways to not communicate. Get the message?

Sloppy PINmanship

An AIM-7M Sparrow missile held captive in one of the missile wells beneath an F-15 was ruined (required depot repair) when its gas grain generator and thermal battery fired. And it couldn't have happened at a worse time, right in the middle of a sortie surge exercise. But that wasn't the worst of it. Another missile hung on the same station about 20 hours later suffered the same fate.

The culprit? An incorrectly modified umbilical wafer, the cannon plug connector that fits into the side of the missile and electrically hooks it up to the aircraft's fire control system.

One of the alterations that tames a captive AIM-7 missile is its modified connector. By removing two specific pins inside a standard umbilical wafer connector, electrical current is prevented from finding its way to the gas grain generator. Then the modified umbilical connectors are wrapped with reflective tape; so it's easy to identify them for use exclusively with captive

missiles. Solid procedure — only whoever cut the pins inside this connector didn't choose the right two. A case of faulty PINmanship.

How come two missiles? Why didn't someone discover the faulty umbilical earlier when the first missile was damaged? They did. But it wasn't immediately removed. Why? Well, it had been a long, busy sortie surge filled with many weapons operations. Then there was a shift change. When the wafer was finally pulled from the aircraft, it was checked by someone on the flight line who apparently didn't recognize it as an unsuitable substitute. So it was reinstalled on the aircraft.

The second missile was uploaded without any problems. But later when a load crew was prepping the aircraft for its next sortie, apparently static electricity generated by the workers' activity around the aircraft found its way through the faulty connector to the missile's guidance unit. Pop! White smoke poured from the missile.

Many of us move from base to base in the service of our country. Others finish tech school and show up for just one tour before leaving. Either way, people who are *not* familiar with local procedures and routines *come*, and people who are go. The constant turnover in the work force is one reason we seem to have so many exercises, to train the new guy. We need to remember that it's not only our job to train them. It's also our job to keep in mind what they don't know in the meantime — even in the midst of sortie surge exercises.

TAG

tips

INTEREST ITEMS,

Cable fable II

A three-ship of F-106s had to divert to a nearby joint-use field when a thunderstorm at the home 'drome cut them out of the pattern. When the weather cleared and the jets had been serviced, the lead element lined up and took off. Number three followed suit ten seconds later. When three rolled across the approach-end cable, the wire bounced up and grabbed both of the aircraft's main gear doors. When the aircraft lifted off and the pilot raised the gear handle, the Landing Gear Unsafe light came on.

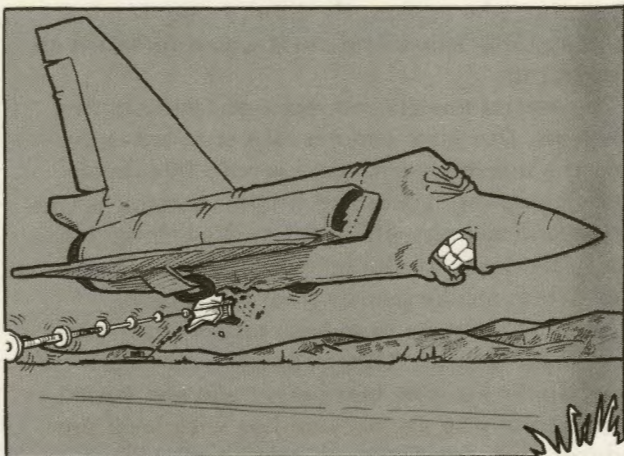

After join-up, the flight lead gave number three a good looking over and told him about the missing hardware. Three lowered the landing gear normally and was greeted with a down-and-locked indication. After burning down fuel, a chat with the SOF and a controllability check, he landed uneventfully.

Over the years there have been a number of incidents where cables have jumped up and ripped off various appendages of unsuspecting aircraft that were taking off . . . especially at joint-use airfields (serving both fighter and heavy aircraft) with BAK-12 cables strung across the runway near the touchdown zone. Apparently, keeping proper tension on a cable with heavies frequently rolling across it is difficult. The long-term fix is replacing the BAK-12 cables with retractable BAK-14s.

In the meantime, what about airfields (joint-use and otherwise) with BAK-12 cables that you might have to consider as emergency/divert bases? If the local area doesn't have any, how about cross-country missions? The slack cable hazard could be even more of a problem if you have to make an approach-end arrestment. In those cases, a call ahead to tower asking for barrier maintenance service before your arrival could pay dividends.

Hung up

The modified connector that the G-suit hose mates with in the F-16 cockpit is a wonderful thing in flight. It's fairly successful at keeping the hose from popping out when the pilot quickly increases the G-load. But nothing is free. Difficulty unplugging the connector on the ground may be the price.

When a Falcon pilot pulled into his parking

MISHAPS WITH MORALS, FOR THE TAC AIRCREWMAN

spot after landing, he lowered the ejection seat and began unstrapping some of the hardware that held him to the seat while the crew chief was installing the wheel chocks. When he pulled on the hose to unplug his G-suit, it was harder to connect than he anticipated; his hand slipped off the G-suit hose and banged up against the throttle, shoving it forward to about 80 percent rpm. Before he could react, the aircraft lurched forward, jumped the chocks and nearly picked up five points for running down the crew chief who was trying to pin the gear. Close.

A good solid tug straight out from the hose is what it takes to disconnect. Side force complicates the issue. Good thing to remember—anytime you might need to make a quick dash from the cockpit during an emergency ground egress. But when the crew chief is underneath your jet, your hands should be visible, not busy doing little cockpit tasks.

No sweat, GI

Number two rolled out of the base turn as lead was touching down. Good spacing. Nice pattern. No sweat, GI.

After touching down on the wet runway, two pulled out the speed boards and pulled up the nose of his A-10 to aerobrake. When he ran out of lift, the pilot lowered the nosewheel back into the water, brought the speedbrakes back in to about 40 percent extension and tapped the brakes to

see if they were alive. They were. No sweat, GI.

About 2,000 feet from the end of the runway, the pilot decided it was time to get serious about stopping. But the harder he pressed on the brake pedals, the less likely it appeared the Warthog was going to stop.

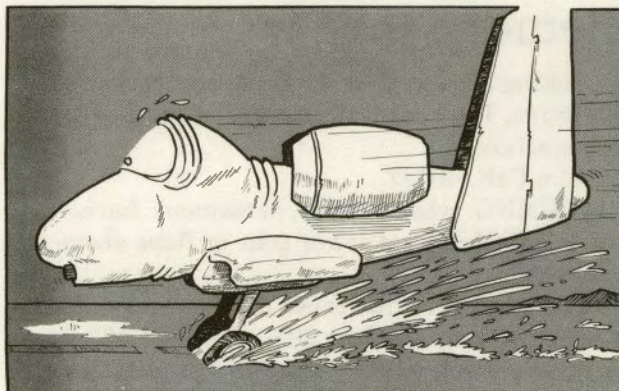

In textbook fashion, as the pilot saw the overrun closing fast at 12 o'clock, he switched off the antiskid and pumped hard on the binders. The A-10's wheels continued to sail along on top of the rain-drenched runway that was adorned with paint and rubber deposits.

In desperation, the pilot then reached up and grabbed the emergency brake handle. Whoosh! The canopy departed the aircraft about 150 feet before the aircraft slid into the overrun. Realizing he had mistakenly grabbed the canopy jet-tison handle, the pilot let go and pulled the brake handle. With emergency brakes on the porous overrun surface, the aircraft stopped readily.

By choosing to delay braking until the last couple of thousand feet of a rain-slick runway,

another pilot asked more of his aircraft's stopping devices than Mother Nature was willing to give up. Somewhat familiar story: a little extra speed on final (Warthogs landed on-speed usually don't lend themselves to aerobraking), retracting speedbrakes that were working just fine and switching off the antiskid . . .

Most flight manuals mention that paint and rubber deposits normally found at the ends of the runway can complicate the stopping problem when it's wet. With April showers and all that, we'd better believe it.

The tape-over-counter memory jogger

Looking around the cockpit of my trusty Rhino, I spy several placards of little or no consequence:

- Radio Call: 40427.
- LANDING: wheels, flaps, armament, harness.
- CAUTION: Do not lower gear or flaps above 250 knots.

Memory joggers like these have collected on the firewall over the last 20+ years (64-027 was flying in combat while I was worried about college entrance exams). Makes you wonder who or what they had in mind when they stuck those things on the dashboard.

Now I'll admit to being glad the tail number is cleverly disguised there as radio call. When you call maintenance, they don't care about your call sign, they want your jet's tail number. If you've climbed in and out of several spares, that's one little bit of info that's probably not on your mission data card. But the other two placards are next to useless (or let's hope so).

While trying to start our hearts one morning over a cup of coffee, Bill Meeker, the Studies and Analysis guy, recommended we come up with a more useful sticker. We were discussing the recent rash of incidents and accidents where internal wing fuel failed to transfer. We agreed that a

memory jogger would help because slightly askew tape-over-counter fuel readings are insidious and difficult to recognize in the midst of a busy low level, range, or BFM mission.

So here is Bill's idea for a trapped gas detector (suitable for gluing to the checklist page of your choice). This little transfer schedule won't give you an *exact* answer, but it's close.

Just in case it's not obvious, the figures on the right side of the chart indicate full fuselage tanks. At the left side of the chart, the internal wing tanks should be empty and the tape-over-counter marriage should endure until flameout (or in E and G models until autotransfer).

Hard wing models with six fuselage fuel cells:

5.3	6.3	7.2	8.2
I-----I	I-----I	I-----I	I-----I
5.3	7.6	9.9	12.2

E and G models with seven fuselage fuel cells:

5.3	6.3	7.2	8.2
I-----I	I-----I	I-----I	I-----I
6.0	8.3	10.6	12.9

The schedule does *not* take into account—

- jets with foam tanks (subtract approximately ten percent from all the numbs),
- burning JP-8 or JP-5, or
- using 5/6 Lockout.

Tolerances are about +/- 300 pounds in most regimes according to Mr. Bobby Moore, the MCAIR tech rep here at HQ TAC who's been around since the Phantom was a gleam in someone's eye.

The spread between tape and counter will be higher than indicated on the chart if you're in burner or maneuvering in the vertical. If you get more than about 2,000 pounds off schedule during any flight conditions, you might consider a knock-it-off and another gas check in straight and level flight.

One final point: this idea should make it easier to detect trapped wing fuel before you're in trouble. But if you don't (1) look at the fuel gauge and (2) think about what it's telling you, this little memory jogger isn't going to save you.

Fly smart (and check gas).

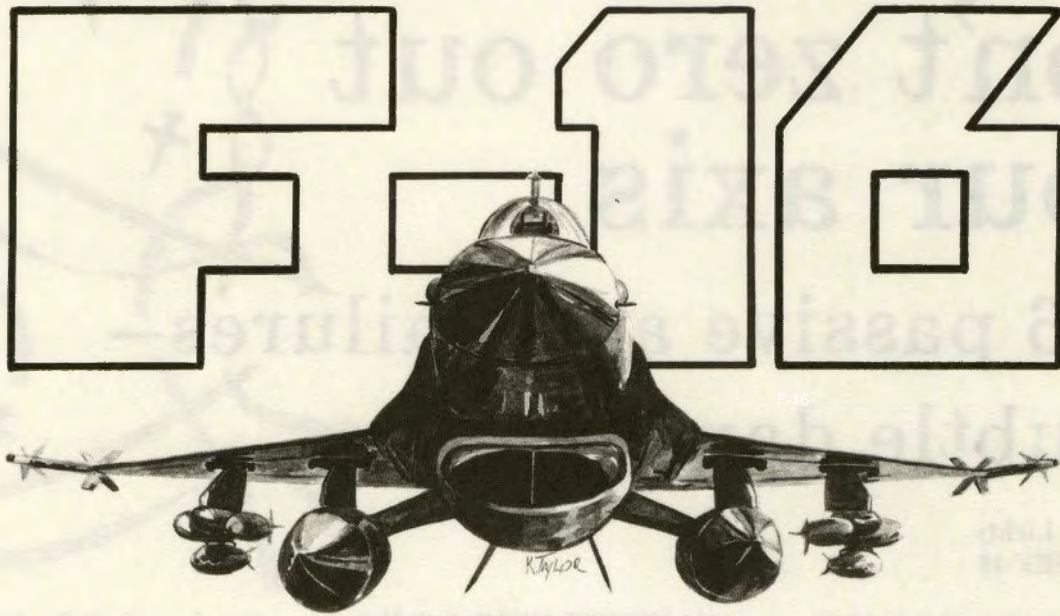

EMERGENCY SITUATION TRAINING

Maj Rich Grinnell
HQ TAC/DOV

SITUATION: As you move the throttle of your sleek and racey electric jet into max AB, you and your load of twin 370s and six inert MK-82s roar down the runway. When you come out of AB (bet you think this will be a loss of thrust—it's not, but do you know off the top of your head what you'd do?), things get real quiet. You lose all avionics. "Caution, Caution" rings in your ear. The Master Caution, Elec Sys and Main Generator lights are shining at you, but EPU Run light is not. The Air and Hydrazine lights are ON as are some others; they are all telling you the EPU didn't pick up the load. What'cha gonna do now, Ace?

OPTIONS: A. Jettison stores and bend it around for an opposite-direction full stop.

B. Turn the EPU ON and see if it picks up the

C. Push the power up to a minimum of 80 percent to give the EPU an extra shot of bleed air.

D. Try to reset the generator; if electrical power

is not restored, you are committed to a heavy-weight landing.

DISCUSSION: Option A would be nice, but you can't jettison anything unless either the generator or EPU is on-line. Option B probably won't work—the Air light tells you the EPU has already received a start command—but it's worth a try. Since a Hydrazine light only means it's being commanded, not necessarily available, a little extra bleed air (Option C) might help an under-speeding EPU. Whether or not Option C works, Option D is a player. Burning down gas with open speedbrakes (they won't) and extended gear (alternate extension) is a luxury you may not be able to afford. Unfortunately, the hook, brakes and UHF work off the battery, and the flight manual says to plan on landing within 30 minutes. Without the new FLCS PMG, your flight controls are also fly-by-battery.

Get the hook down early, and don't use the radio any more than necessary. An approach-end arrestment with all that weight? Departure-end? In any case, stay alert for degraded aircraft response and eject if it's not flying right. ➤

don't zero out your axis

F-16 passive axis failures— a subtle danger

Maj Mike Lichty
HQ TAC/SEF-16

The Aggressors are in town and you're right in the middle of a 2-v-2. Your wingman has ripped the lips off the lead F-5, and you're getting ready to turn the heater on his wingman. As you roll and pull into the plane, you're distracted by the Master Caution, Flt Cont Sys (Flight Control System) Caution and R (roll axis) lights. @*# +! The DRPCB (dirty rotten . . .) is going to get away again . . .

"Knock it off, knock it off, knock it off. Viper 1 has an FCS light." The jet seems to be controllable enough. Looks like a passive axis failure. No sweat. Time to reset the lights and nail that DRPCB in the next engagement, right? Not so fast . . .

Within the last year, as the contractor has reviewed memory dumps from several F-16s, guess what's been found? The tapes reveal that some pilots have repeatedly tried Flt Cont Sys, Elec, or Servo resets to clear illuminated flight control axis lights (P, R or Y) or Servo Mal lights. A pilot using this technique is not

only ignoring guidance in the tech order, but also unnecessarily risking loss of control.

A passive axis failure can occur at any time regardless of flight conditions and causes a loss of signal from a single flight control system branch into the mid-value selector.

The passive failure is not detected in straight and level flight since the failed branch is being compared to the three active branches whose outputs are also near zero (therefore, below the detection or voting threshold).

In maneuvering flight, however, the failure is detected as the outputs from the three active branches rise above the voting threshold and the failed branch remains at zero, thus illuminating the Master Caution, Flt Cont Sys Caution and appropriate axis lights. When this occurs, it's important to remember three things:

1) If, for whatever reason, you're not in a position to do a similar maneuver to see if it trips the light(s) again, do not

reset the axis light, but do a CAUTION RESET to put out the Flt Cont Sys Caution and the Master Caution lights.

If you do an ELEC RESET, a subsequent failure in another branch may cause loss of that axis and loss of control.

2) If the light is reset more than once, subsequent failure in another branch of that axis may cause loss of that axis and loss of control.

3) If the light won't reset, or if the light comes on again once it's been reset, do not attempt further resets and land as soon as practical.

Improper handling of a passive failure can set you up to be an ACES II test pilot. If I've jogged your memory enough to bring back RTU flight control system academics, enough said. However, if you need a refresher and your wing can't afford to fund the TDY, read on.

First, let's look inside the flight control computer. Figure 1 is a simplified sketch of one of the four quad mid-value selectors (MVS).

The signal selector concept

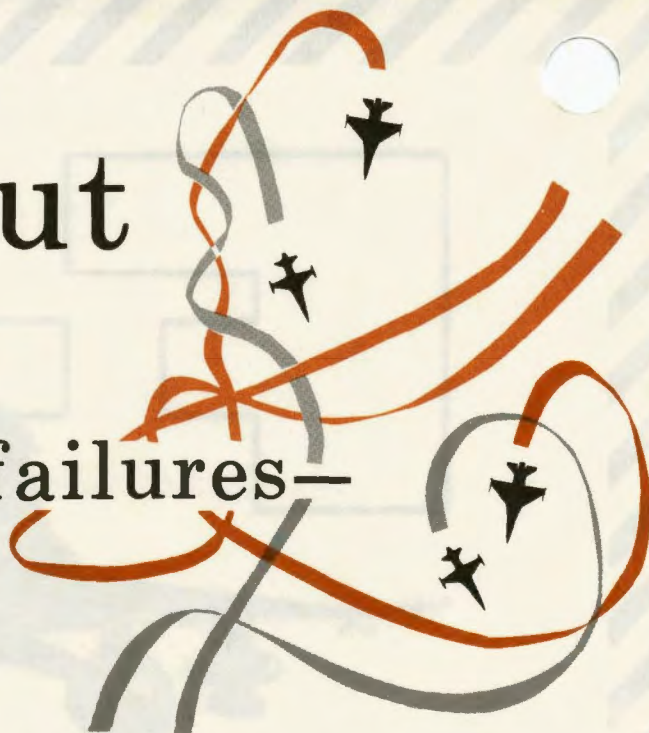

incorporates an MVS voting scheme with a redundancy feature. In the normal (no failure) condition, Branch D in each selector is switched to a standby condition, and the signal selector functions as a middle-value voter for the three remaining branch signals. The middle value of branches A, B and C is selected while all four branches are continuously monitored. In the event of failure, the failed branch is detected and switched out. At the same time, Branch D is switched from a standby to active status and replaces the failed branch, provided Branch D too, has not failed. After a second (i.e., dual) failure, the signal nearest zero is selected and passed to the servoamplifiers.

What happens if there is a dual passive failure? Figure 2 illustrates that a passive failure has occurred in Branch A.

The failure has been detected, Branch A has been switched out and Branch D has been switched in. The Axis and Flt Cont Sys Caution lights will be illuminated. Once the aircraft has returned to straight and level (e.g. non-maneuvering flight), when the pilot initiates ELEC RESET, the selector monitor will reset and the lights will extinguish. That's what happened in figure 3. Branch A has been reset although the passive failure still exists, and Branch D has been returned to a standby position.

0 inputs at Branches B, C, and D (that replace the + inputs in figure 2) indicate non-maneuvering flight.

Figure 1

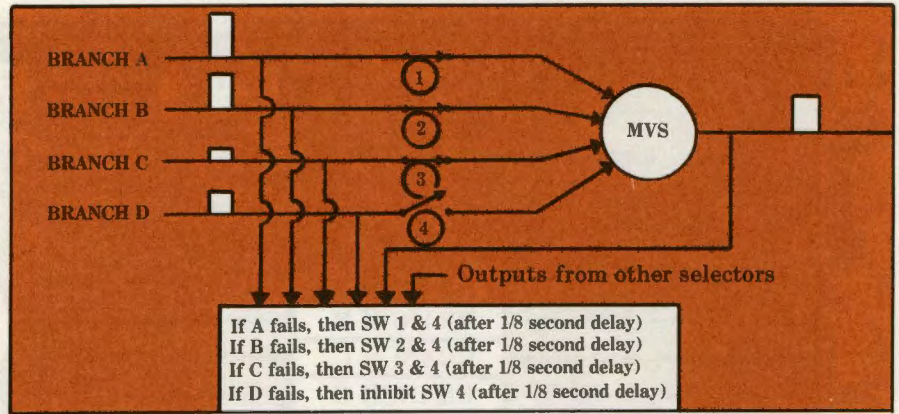
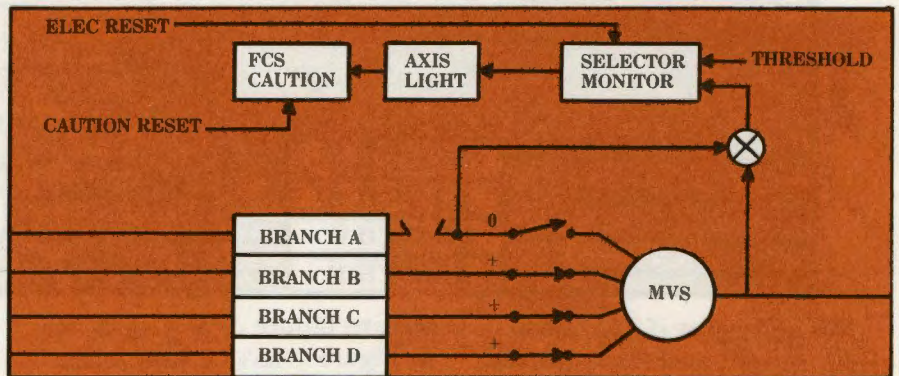

Figure 2





don't zero out your axis

Figure 3

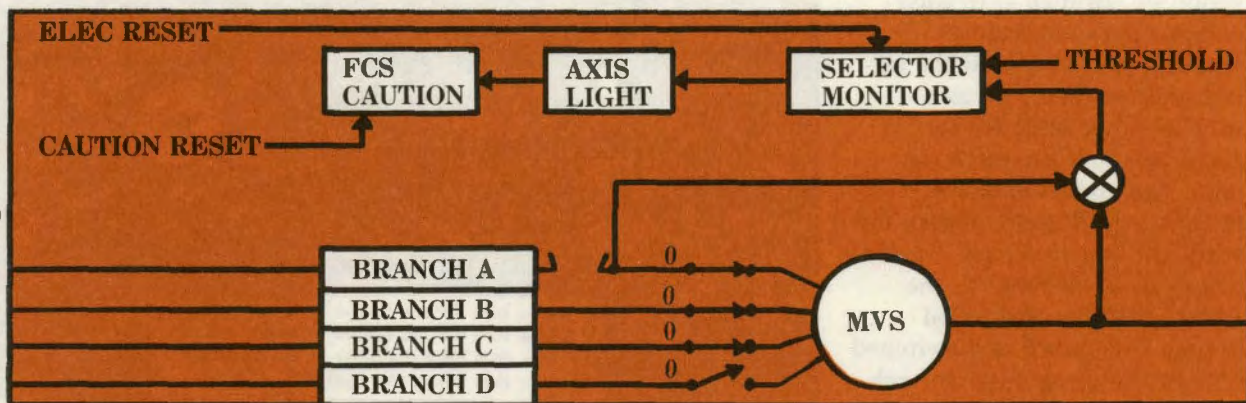
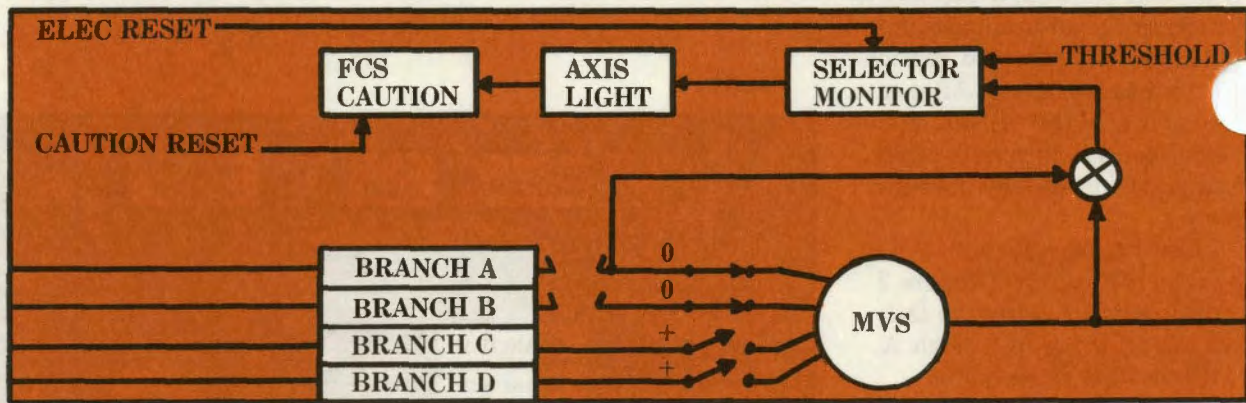

Figure 4



We know that if ELEC RESET occurs in nonmaneuvering flight, the pilot should initiate a maneuver in the same axis as soon as possible. If the lights come on again, the CAUTION RESET switch should be pressed. That will extinguish the Flt Cont Sys Caution light and leave the selectors the way they were in Figure 2 with the faulty Branch A switched out.

Let's say that the pilot has electrically reset and left the selectors as shown in Figure 3 with a Branch A passive failure. If he flies for a period of time without maneuvering, the stage has been set; if a second

passive failure occurs, as shown in Figure 4, he's in deep serious.

The selectors are set to select the mid-value of Branches A, B and C. However, passive failures have occurred in Branches A and B. As the aircraft maneuvers (indicated by + at Branches C and D), the selector monitors see that Branch C does not compare with Branches A and B; therefore, a Branch C failure is detected. Branch C is switched out and Branch D is switched in. As Branch D is now compared to Branches A and B, it also doesn't agree. So the selector switches Branch D back out

and a dual failure occurs.

After a dual failure, the selector will choose the lowest of the two *unswitched* inputs. Since both A and B inputs are zero, the resultant selector outputs will be zero. Bad news if this happens in the pitch selector.

For your own safety, heed the three warnings under the P, R and Y malfunctions in the emergency procedures section of the Dash One. Remember, the emphasis here is on passive failures, not nuisance lights caused by things like flying near certain HF antennas.

ACES II is batting one thousand, but why press your luck? >

HELP WANTED:

The USAF Bird/Aircraft Strike Hazard (BASH) team is hosting a bird hazard reduction conference at Vandenburg AFB, California, 13-16 May 1985. The conference is open to anyone currently dealing with bird problems at a military flying installation. The conference will deal exclusively with the unique considerations of military flying operations including reducing the risk of flight, bird control at the airfield (a full day) and new developments.

If interested in attending, contact your MAJCOM/SEF (for TAC, HQ TAC/SES, Langley AFB, Virginia 23665-5001, AV 432-3814). Travel orders required for billing at Vandenburg AFB. Any questions, contact the BASH team, HQ AFESC/DEVN, Tyndall AFB, Florida 32403-5000, AV 970-6242 or 43.

The USAF Survival School wants your survival episode. If you've been involved in a survival situation (regardless of the length of time or the circumstances), they would like to hear from you. They'd like to include your experience to update their lesson plans to help teach and motivate others.

Send your *There I Was* survival story, handwritten or typed, to 3636 CCTW/DOV, Fairchild AFB, Washington 99011-6024, or call MSgt Edgar at AV 352-2371.

HELP WANTED: Major fighter pilot who needs a staff (ptooey) tour and thinks he could do worse than Langley AFB, Virginia;

- writes well;
- would like the opportunity to help other pilots and the folks who help get him airborne;
- wouldn't mind autographing 16,500 copies of *TAC Attack* each month;
- can be in place by May/June 1985.

If that's you, give me a call at AV 432-3658, and I'll be happy to tell it to ya straight. I don't know what else to tell you except the entire staff is anxious for you to get here 'cause I'm outta here in July. If that's not enough,

- Stan has a boat;
- Marty is single and has an IRA;
- and Kelvin won't stipple on your rough drafts if you're nice to him.

Lew Witt, Editor
TAC Attack Magazine

HEADS UP

Next month in the

MAY

issue of *TAC Attack* you can look forward to seeing the F-16 Falcon IN THE CENTER.

F-16C FALCON

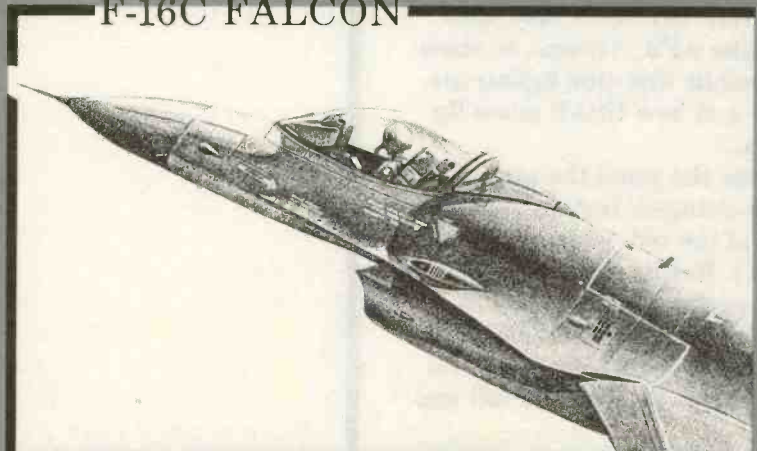

USAF Thunderbirds



The USAF *Thunderbirds* were formed in May 1953 at Luke AFB, Arizona, to show the public first-line fighter aircraft and how USAF pilots fly them.

Over the years the aircraft have changed. Instant recognition of the red, white and blue hasn't. Neither has the thrill that excites the little boy in men in blue like me who stand about two feet taller when the *Thunderbirds* roar and roll and loop.

When they're in town, I'll be there. ➤



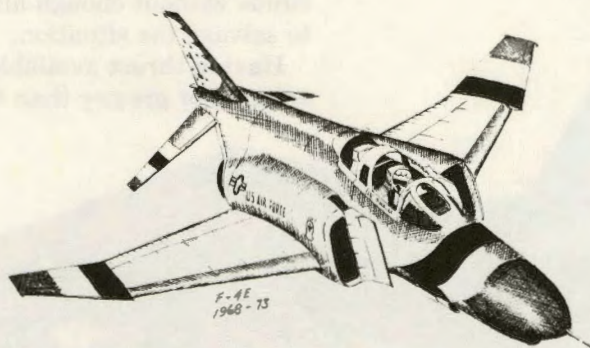
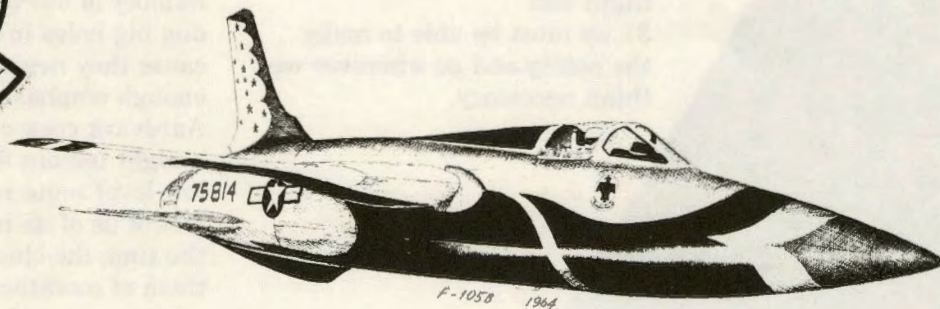
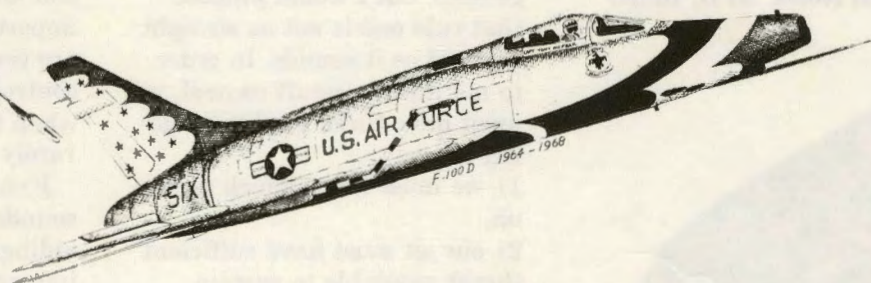

"THE THUNDERBIRD TRADITION"
— LIMITED EDITION —
by
BOB SIMPSON

Bob Simpson

Emergency R.O.E.

Lt Col Robert D. Mielbrecht
Chief, Wing Safety
366 TFW
Mountain Home AFB, Idaho

All crew members are familiar with the three basic rules for handling emergencies, but I would propose that rule one is not as straight forward as it sounds. In order to maintain aircraft control, we must have three conditions going for us:

- 1) we must know which way is up,
- 2) our jet must have sufficient thrust available to sustain flight and
- 3) we must be able to make the pointy end go wherever we think necessary.

The tendency is to consider condition three as synonymous with maintaining aircraft control, but it is probably the least important of the three. Pilots are conditioned from day-one to control aircraft attitude; but when they can't, crew members rarely delay ejection.

Knowing which way is up sounds simple and it is, providing we never lose sight of its importance. Unfortunately, a number of our brothers have dug big holes in the ground because they neglected giving it enough emphasis. Recently, an Aardvark crew climbing out of a night terrain following radar low-level route reminded the rest of us of its importance. By the time the clue bird reminded them of condition one, they were in a nose-low unusual attitude without enough altitude to salvage the situation.

Having thrust available equal to or greater than thrust



required is also a biggie. If your JP-4 converters are not producing enough heat, smoke and noise, you're not going to be able to maintain aircraft control for very long. Case in point was a fellow fighter crew across the pond that took a bird on the beak during a 550-knot bomb run-in. When the fiberglass radome collapsed, they started a climb and turned towards the nearest field.

Shortly thereafter, they decided that their ability to comply with basic rule one was deteriorating and they ejected. What they didn't know was that both engines had stalled, they were rapidly running out of smash and had they delayed ejection a little longer, the ensuing post-stall gyration may have put them out of the envelope. So ignoring the importance of available thrust can also kill.

That brings us to keeping the pointy end forward. The flight control systems on most newer fighters look something like this block diagram.

Block 1 problems are usually personal, and we'll ignore them here. (But you can only do so much of that in real life.) Troubles in Block 3 or 4 usually result in conditions where ejection is the only alternative. However, Block 2 problems can be a real player in maintaining aircraft control. Of course, if time and circumstances permit, you can dig out your trusty checklist (or ask your right/backseater, if you're lucky enough to have one, to dig into his) and see if any of several dozen procedures for flight control malfunctions describes something akin to your current predicament.

Like most things built by the lowest bidder, Block 2 systems think they are smarter than fighter pilots, and sometimes your only recourse is to pull the plug. In the case of the 550-knot birdstrike at low-level, the collapsing radome damaged the angle of attack probes causing the stall inhibitor system to drive the nose up and down in

response to erroneous AOA indications. The point is, if maintaining control is in jeopardy, turn off the offending magic, pronto. But be prepared to immediately reactivate the system if it turns out to be helping.

Having a solid grasp of the three basic rules for handling aircraft emergencies is not enough. To maintain aircraft control requires three additional things: never lose sight of which way is up (lest the clue bird beat a retreat into your G-suit pocket), insure that thrust available is at least equal to drag and if the pushrods are having a problem, try eliminating the middle man.

Lt Col Mielbrecht has over 3,000 hours in the F-111, 4,000 hours fighter time. He has served as an IP and SEFE in TAC, USAFE and PACAF. Currently he is the Chief of Safety at Mountain Home AFB, Idaho.

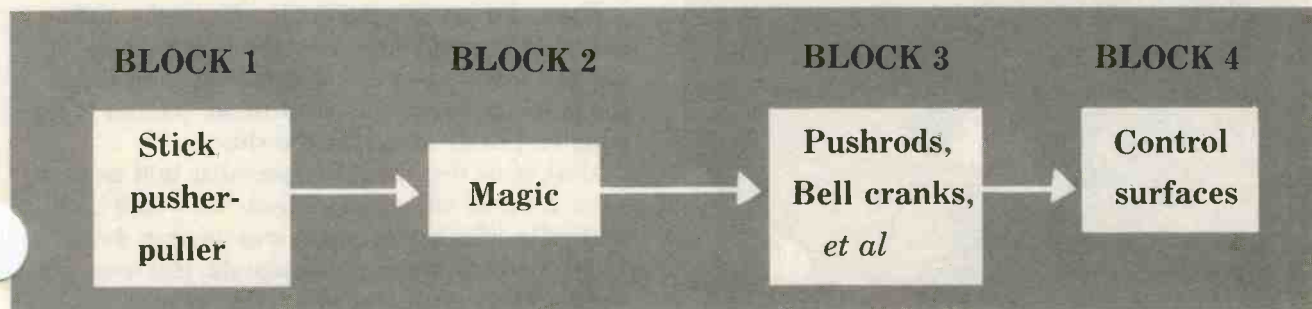

CHOCK TALK

Chock Talk

Incident and

INCIDENTS AND

Patchwork

A couple of RF-4s completed a series of defensive maneuvering engagements that involved supersonic and high-G flight. The leader then rejoined the wingman to look over his aircraft. One of the reasons for this routine check that always follows an air-to-air workout is to alert the pilot to any structural damage that might have occurred before the aircraft returns to the slow-speed landing environment.

A metal strip at the wing fold junction on top of the Phantom's wing was missing. The piece that didn't make the return trip wasn't a little dollar panel or a lens cover; it was a two-by-twenty-four-inch strip of sheet metal. Must've been a major over-G to rip the hefty part from

the wing, right? Nope. All it took was a lack of communication.

About a month before the missing hardware incident, during a post-flight inspection, someone discovered that the four-by-eight-inch patch that re-enforced the metal strip was loose. The discrepancy was written in the aircraft forms (AFTO Form 781A).

A sheet metal specialist took a look at the patch and determined it would hold long enough for a new one to be ordered. After he ordered the new part, he told the crew chief to inspect the patch after every flight and released the aircraft for flight. But he never documented the inspection requirement.

When the new wing fold was ordered, someone transferred the write-up to the back of the aircraft forms, the 781K. Later, when a new 781K was transcribed, the write-up about the patch was inadvertently dropped. Soon the inspection requirement was forgotten. So the aircraft continued to fly, but no one was keeping tabs on the patchwork.

Then, during this particular flight the airflow most likely snuck up under the leading edge of the patch and caused it to separate. And when the patch gave up, the sheet metal section of the wing fold came along for the ride.

Most of us feel that if a specialist told us to inspect an area after every flight, we would do it faithfully whether or not it was written down. That's because we're professionals. But even professionals get sick, are sent TDY, take leave, etc. Get the point?

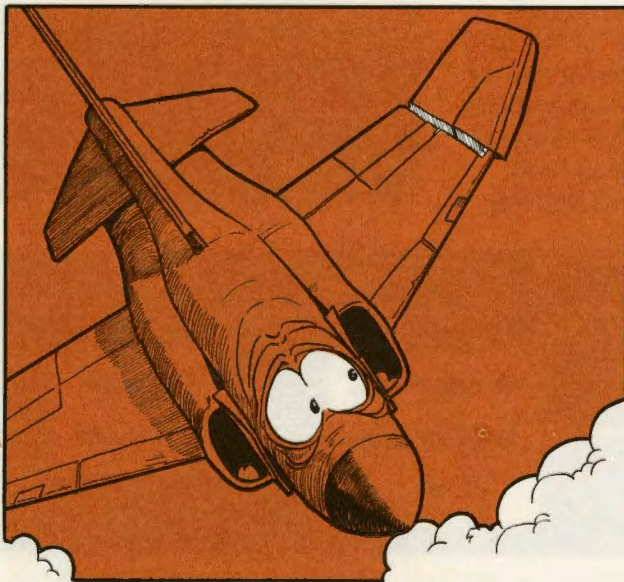

INCIDENTALS WITH A MAINTENANCE SLANT

Brief debrief

During a realistic training exercise, an F-15 pilot flying an intercept mission with his fangs out suddenly forgot about shooting the bad guys. He was booking along at .9 Mach at 10,000 feet when he heard and felt a *thump*. Then the red light in the landing gear handle came on.

When the pilot called his wingman over to take a look, the wingman delivered some bad news: one of the gear doors on the leader's aircraft was missing and another was flapping in the breeze. The pilot declared an emergency and lowered the landing gear on the way back to base. The gear gave a positive down and locked indication. The subsequent landing was uneventful—but neither the normal nor emergency brakes worked during the rollout. Fortunately, the tailhook worked and snagged the departure-end cable.

What's up, Doc? What would make the gear come down of its own volition? Thirteen sorties earlier, a similar event took place. When the pilot noticed the unsafe gear indication, he cycled the gear handle, the light went out, so he pressed on. About five minutes later, however, the light came on again; that convinced the pilot to abort the mission and bring the aircraft home.

During debrief, the pilot described what happened and the technician entered a fault code in the aircraft forms. Somehow, the wrong fault code ended up in the forms. Repairmen used the appropriate troubleshooting procedure that matched the fault

code in the forms; a more thorough inspection (required by the correct fault code) more than likely would have revealed the real problem.

We don't know how thorough the debriefing was. But one thing we do know—even though sometimes the paperwork seems like nuisance, doing it correctly is the only way to make sure the right job gets done.

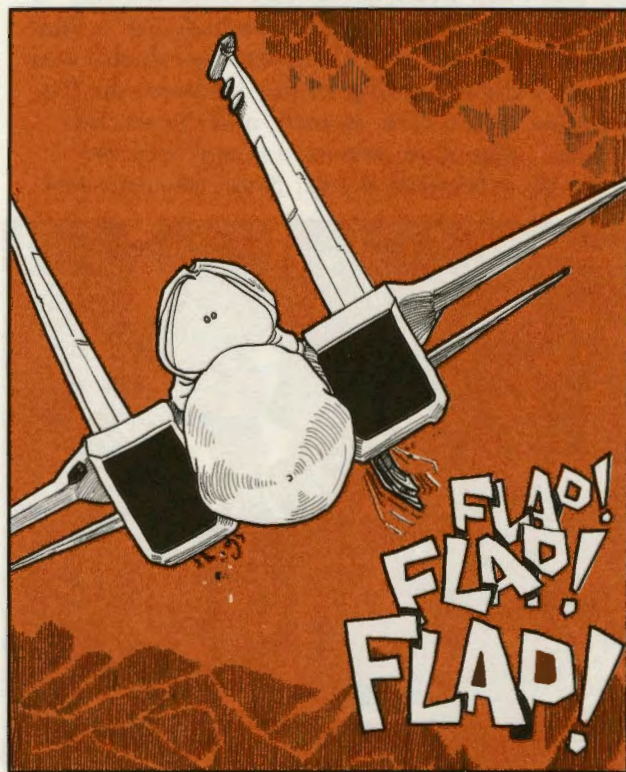

Extra help—no thanks

About nine minutes after takeoff, an F-4 crew heard a loud *thump* similar to what it sounds like when you fly through jet wash—only there was no jet wash around because this aircraft was single-ship. Next, the left Fire light greeted the pilot. When he retarded the throttle, the warning light went out; so he left the throttle in idle and turned the aircraft towards home. Everything else seemed to be working OK on the way back to an uneventful landing.

Troubleshooters soon found the culprit, a V-band clamp on the bleed air ductwork inside the midsection of the fuselage. The clamp wasn't properly seated and eventually worked loose. Before long the ducting separated and began blowing 800-degree air all around the Phantom's interior.

Bleed air duct failure is one of the most serious F-4 emergencies because there are no reliable warning signals to the aircrew. The extreme temperature can cause severe structural damage to the aircraft. Over the years we have lost a number of Phantoms after their bleed air ducts came apart in flight. Luckily in this incident, the fire warning loop was in its path, and the aircrew landed before more serious damage occurred.

Faulty overpriced clamp? Nope. Someone had

installed two metal O-rings, instead of the one that the TO calls for, when they assembled the clamp. Maybe they thought "If one is good, two must be better." More likely they were just pre-occupied or distracted and not aware of the extra O-ring.

When we hear stories of \$5,000 coffee pots and \$84 screw drivers, a nine-cent O-ring sounds like a bargain. But in this case it almost cost us plenty. Let's not accept that kind of extra help. Better to mind our Ps, Qs and O-rings.

Speedy

An A-10 was up on an acceptance flight following major maintenance. Everytime the FCF pilot tried to speed up for the speedbrake blow back test, the Warthog would wobble with pitch oscillations. When he'd slow down again, the aircraft was stable. Each time he lowered the nose and tried to accelerate, the same thing would happen. The pilot finally got the message and took the path of least resistance—slow. Then he brought the aircraft back for an uneventful landing.

Troubleshooters found the computer that controls the aircraft's stability augmentation wasn't bolted in place. With the SAS computer running around loose like that, certain aircraft maneuvers made it jiggle around, sending faulty inputs to the aircraft's flight controls. Since it's highly unlikely that both bolts vibrated loose at the same time, it's more probable that someone borrowed the computer while the aircraft was down for maintenance. But you couldn't prove it from the forms—there were no entries about the SAS computer at all.

We need to be careful to use the aircraft forms. They tell us what has been done to the aircraft as well as what needs to be done—but only if we use them correctly and make the right entries. Slowing down (even in the A-10 community) and taking the time to write in the forms can save hours of extra work and wasted dollars.

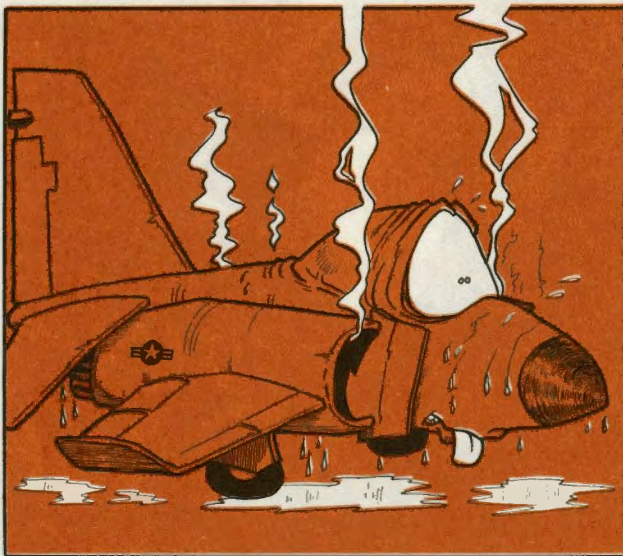

COPING WITH AN INFLIGHT EMERGENCY

O. 1F-16A-1CL-1

OPERATION EP
EMERGENCY PROCEDURES
INDEX

Page

GROUND EMERGENCIES
ANTI-SKID CAUTION LIGHT ...
BRAKE MALFUNCTIONS ...
FUEL/OVERHEAT/FUEL LEAK (GROUND) ...

HUNG START ...
HYDRAZINE LEAK ...
MAIN GENERATOR FAILURE (GROUND) ...
NLG WOW SWITCH FAILURE ...
NWS FAILURE/HARDOVER ...
TAKEOFF EMERGENCIES

ABORT ...
AB FAILURE ON TAKEOFF ...
BLOWN TIRE ...
ENGINE FAILURE ON TAKEOFF ...
ENGINE FIRE ...
LG FAILS TO RETRACT ...
LG HANDLE WILL NOT RAISE ...
LOW THRUST ON TAKEOFF ...

Maj Tom Dean
F-16 Functional Manager
HQ TAC/DOO

Cope with an inflight emergency? You bet I can. I've always got my checklist with me in my G-suit pocket, don't I? If you feel that's the level of knowledge you need to deal with any emergency that requires reference to the checklist, then don't step over this article—it's aimed at you.

The School of Hard Knocks teaches that you can pursue three basic activities on the ground before flight that will significantly enhance your ability to successfully cope with an emergency in the air:

- learn to use the emergency procedure index of your Dash One checklist,
- understand the rationale behind the sequence of steps for each EP and
- develop a plan to pace yourself, to better control the rate

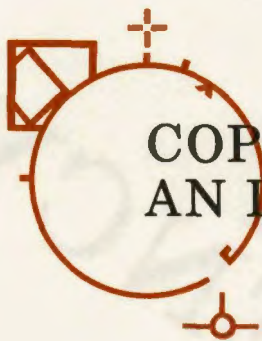

COPING WITH AN INFLIGHT EMERGENCY



at which you respond and react to unplanned events.

First, the fighter pilot who works hard at becoming familiar with the index page of his Dash One checklist will be insurance premiums ahead. Stop and take a few minutes to review the four basic sections of the indexing system covering the emergency procedures: ground, takeoff, inflight and landing. What you are looking for is the *scheme* that was used to systematically list the various emergencies within each phase of flight. For example, are the emergency procedures contained in the inflight section of the index arranged alphabetically or in rank order, from major down to minor? Next, review the procedures within each section to identify those emergencies that require cross-referencing. Can you in fact find the cross-referenced procedure quickly?

The second activity to add to your bag of tricks is the ability to see and follow the rationale for the sequence of the steps in each emergency procedure. Who designs things like that? Someone with a good head on his shoulders, like you.

Picture yourself seated at a conference table in the engineering building of the company that manufactures your aircraft. At your nine, twelve and three o'clock positions are two other Air Force pilots and several company structural and

systems engineers. Your task today is to develop a set of procedural steps that will logically take a pilot or aircrew from the onset of an emergency situation to a successful landing. The sequence of steps you choose must include not only all the required switch actions to keep the aircraft flying, but also the best course of action to work around degraded systems. Ask yourself as you examine each emergency scenario, have you done all that you can for that pilot or aircrew who is relying on your expertise and judgment to bring that aircraft safely home?

That's the process. And because smart people are trying to design a fail-safe system to help you solve a problem with your aircraft, a smart fighter pilot like you should be able to discern their reasoning and rationale. If you can page through the emergency procedures section of your checklist and understand the rationale for the sequence of steps in each procedure, you are *prepared* for any emergency in the checklist. The confidence that this feeling builds is significant. It's well worth your time.

Third, while understanding the layout and scheme of each emergency procedure is important, "referring to the checklist" must first be put in proper perspective. First and foremost, fly the jet. Then, in any emergency situation, is

there any switch that must be thrown *immediately* to maintain aircraft control? If the answer is yes, it is most likely covered by a boldface or critical action procedure, and that's what you should be doing while flying the aircraft. If the answer is no, your reaction should be to maintain aircraft control, analyze the situation while you get pointed away from the ground and headed towards home or some other suitable runway. Those critical initial actions must be done at the *proper pace* to avoid hasty or incorrect actions.

After dealing with these priorities, work on attaining the proper altitude and airspeed for the return trip. While completing the checklist, declare the emergency and request a single frequency approach with ATC.

At this point, when it's time to dig out that checklist (or aircrew aid, or IFR map, etc), your cockpit management can help or hurt you. Do you strap the checklist to your leg or keep it in some other part of the cockpit? If you keep it stowed in some part of the cockpit, is it secure? Will you be able to maintain altitude and airspeed without the checklist ending up on the floor?

Now that it's time to refer to the emergency procedures section of your checklist, you are ready. You know how to let the index help you by choosing the

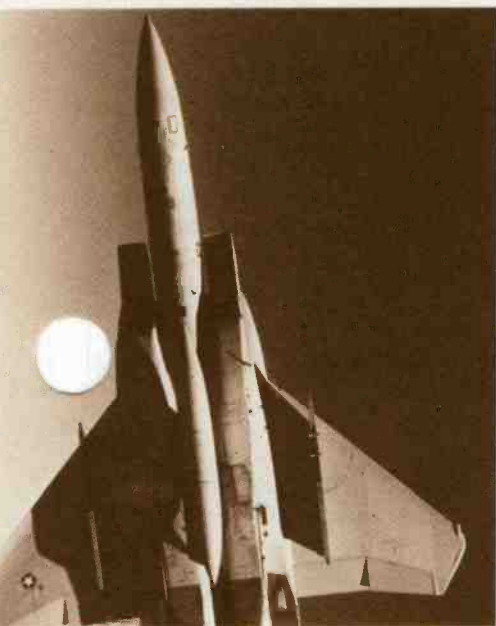
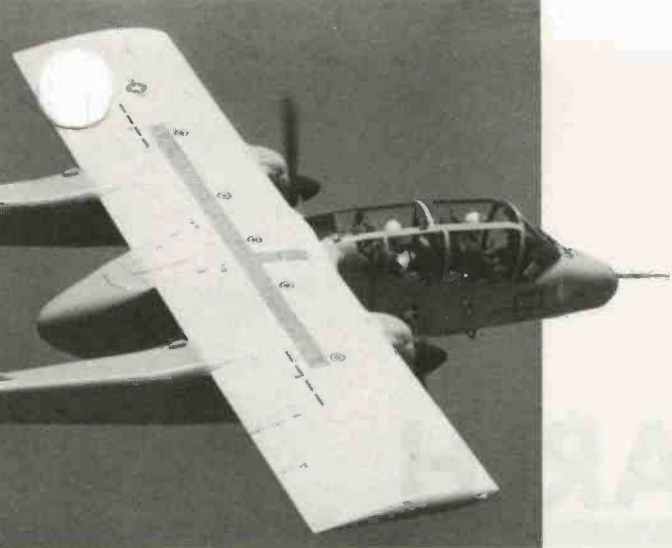

appropriate phase of flight (ground, takeoff, inflight or landing) and then finding the procedure within that section either alphabetically or in rank order.

If the emergency develops close to the field, instead of heading towards home or some other suitable alternate, you may have to obtain maneuvering airspace while you accomplish the checklist procedures and set up for the approach. After all, not every emergency situation requires immediate landing to best cope with the situation.

After you have completed the checklist, contact the SOF and

state your intentions. Pass along the necessary information for the folks who will be supporting you on the ground until you are safely shut down.

The final step is easy—but important. If the type of approach for the emergency is listed in the checklist, then that's what you fly. If it's not defined, select the approach option that provides the greatest safety margin. Then, think about what could go wrong after touchdown. Make a plan to cover some what-ifs, like missed cables or aircraft control difficulties.

The most important thing

during an emergency? Pace yourself—don't rush yourself. Familiarity with the indexing scheme and understanding the rationale for the steps in any emergency procedure will help you pace yourself. Don't confuse proper pace with an inappropriate sense of urgency. The latter can draw you to a faulty conclusion or action that may not be reversible.

Ready to cope with an in-flight emergency? ➤

Maj Dean has about 2,400 flying hours, about 500 hours in the Falcon and previous tours in the F-4 and OV-10. He is one of the few staff officers at HQ TAC who continues to actively fly F-16s.

Envy, envy.

DOWN TO EARTH

Coping with long-term family separations

Brenda Mims
Child Development Center

It's unavoidable: one of you is going away. Not for a week or two, but for a month or two; maybe 12. Whether it's your first long separation or one of many, it isn't a happy time. But there are many ways to lessen the strain of a long absence.

Long-term, nonpermanent separation is unique. It requires the same kinds of adjustments to a single-parent situation that death or divorce does, except the adjustments are temporary rather than permanent. In many families, the absent parent's return may be the biggest problem of all. Adjustments to a one-parent routine

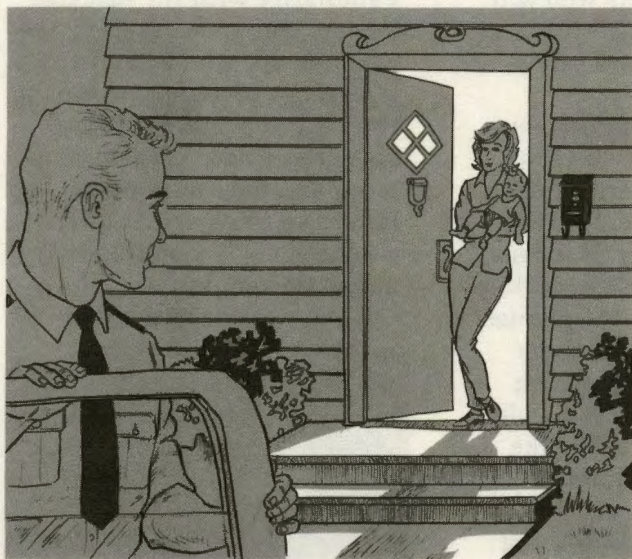

have been made, and suddenly there are two parents again.

While either parent can be absent, it's most often "Daddy." Whether the separation is because of military service, distant job opportunities or illness, it's important to keep the absent parent and the child familiar with each other. The Moody Child Care Center offers the following ideas to keep the memories sharp while Daddy away.

Before the Fact

Tell the kids. Unless they're very small, tell them well ahead of time, emphasizing how much Daddy will dislike not being with you in person, although you'll be in each other's thoughts. Concentrate on having several especially good family times together to recall with pleasure.

Take pictures of Daddy doing ordinary things around the house such as washing the car, sitting in his favorite chair, cooking spaghetti. This is particularly important for younger children with short visual memories. Put the pictures where they can be seen often.

Dad can give a special gift—a scrap book to be filled with post cards, matchbook covers and other mailed mementos.

A Matched Pair

Purchase two tape recorders, one for Dad and one for the family. Many are simple enough for a child to operate, especially if the buttons are coded with colored tape.

Keep a library of tapes of Daddy's voice. He can record family stories or books before he goes so he can still "read" the kids a bedtime story. Keep several tapes stashed away for gloomy day surprises.



“Happy Birthday to You.” On birthdays, Dad can make special tapes, singing and telling anecdotes about the child’s birth and when he was “little.”

Keep it candid—people are more spontaneous when they aren’t actually clutching a mike. Some of your best tapes can be Sunday dinners at grandma’s when, in cloak-and-dagger tradition, tuck the mike in the centerpiece where it would be forgotten.

Keep it handy—a recorder parked on the kitchen table will encourage short messages and comments. Chat while you work around the kitchen and during meals. Another good time is when children burst in from school or play. If it’s all “moans and groans” it can be erased, but Dad is entitled to share the gripes too.

Be faithful—you might make a “date” each day to talk.

Misery is an Empty Mailbox

Write every day—on super-busy days, even a toddler can be enlisted to “write” a post card. Dad will also welcome a short dictated message by one too young to write. In return Dad can make sketches of himself, the place he lives, and what he is doing.

Weigh things carefully—a postal scale is very handy. When you’ve finished a letter, add every last cartoon, clipping of hair from the barber and child’s drawing you can. Write letters on the backs of school work.

Blow-by-blow—if your child is a toddler, take 10 or 20 minutes and write a diary of activities. You can’t do this with a tape recorder, the child will want to listen. But it’s essential to keep the children real to Daddy, too, and it’s the day-to-day scenes he’ll miss. These are the things that don’t

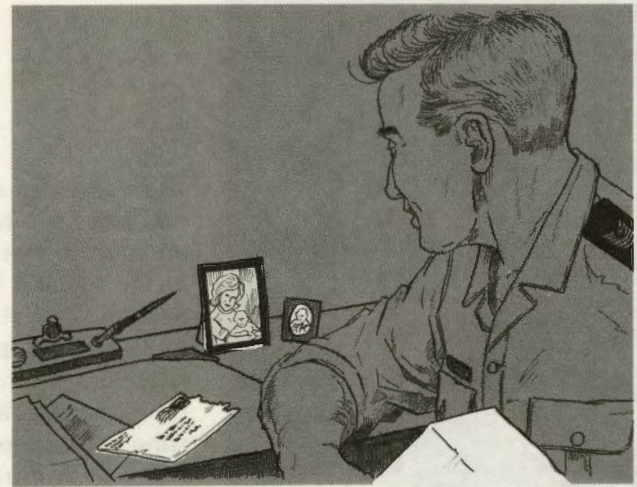

find their way into letters because they’re so “ordinary.”

Daddy should send private, personal messages to each child from time to time, even if they must be read by Mom. They’re a great way to stay in direct contact and may be glued into the scrapbooks to be read again and again.

Talk, Talk, Talk

Talk about Daddy a lot—mention his pet peeves, favorite cookies and things he likes to do: “Daddy always enjoys mowing the lawn.” Comment if you wear a dress Dad especially liked. Bring his opinions into the conversation whenever you can. That more than anything else, perhaps, keeps him real.

When Dad finally does return, you spend very little time getting acquainted. It’s nice that after a long separation you can settle into your own places without tense readjustments.

—Courtesy TAC News Service

PART TIME FLYERS

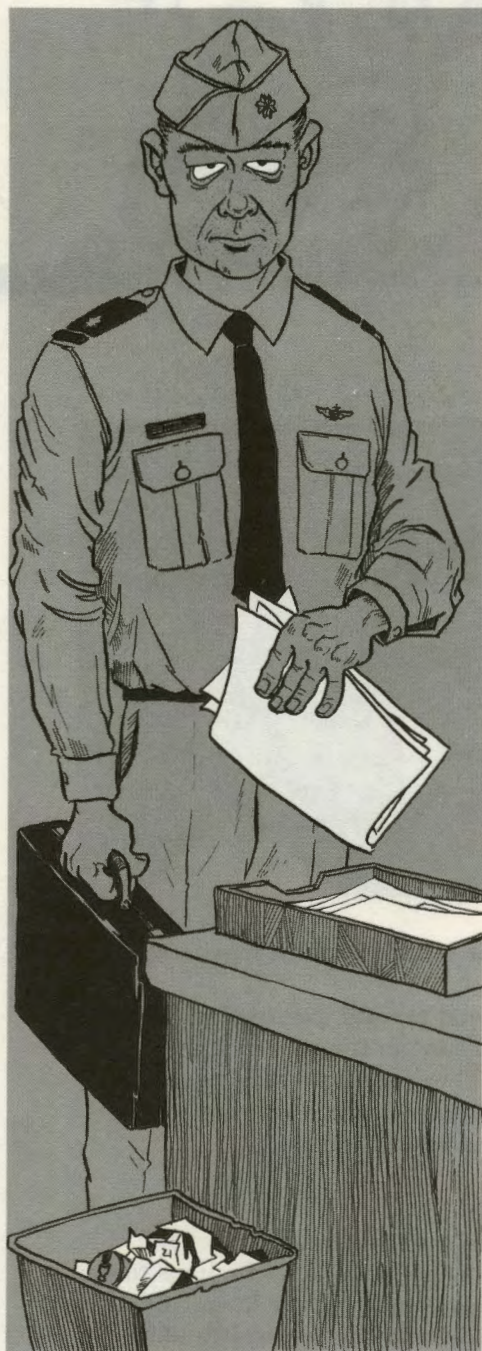

Maj Bob Keeney
F-15 Program Manager
HQ TAC/DOV

Yes, you're an experienced jock; you have 47 patches on your helmet bag, more time at the top of a loop . . . etc. But now you're a staff (ptooey) puke, a wing (ptooey) weenie snivelling flights here and there, scrounging all the flight time you can get out of 30 sorties a half. Funny thing though; despite your credentials and your vast experience, you find yourself making odd-ball errors—forgetting to arm the seat, entering the fight with your speedbrake out, screwing up the pattern. How prepared for degraded systems or emergencies do you think you are? Take heed. These little hints from Mother Nature are telling you that you may be setting yourself up for *the big one* unless you change your attitude. Here are some ways to avoid disaster—or at least keep you from standing in a brace in front of the DO somewhere.

Admit it

Lack of recent experience has taken a little bit of the edge off

those highly polished skills. Time, gravity and that swivel chair behind your LSD have reduced your G-tolerance and raised your comfort level. Maybe your lookout isn't quite as sharp as usual. There's nothing wrong with your hands—it's your thought processes and habit patterns that have become rusty. That doesn't mean you should be put out to pasture or you no longer have anything to contribute. It does mean you need to consider your proficiency and not let yourself be scheduled for an event you're not ready for.

Here's an unscientific depiction of fighter pilot confidence and ability as they decline with time behind the desk. Note the hatched area. At some point, which is different for each individual, declining confidence exceeds declining ability. Operating in this area, you should closely evaluate the mission tasks you are expected to do. It's a great argument for a nondemanding mission after a layoff from flying.

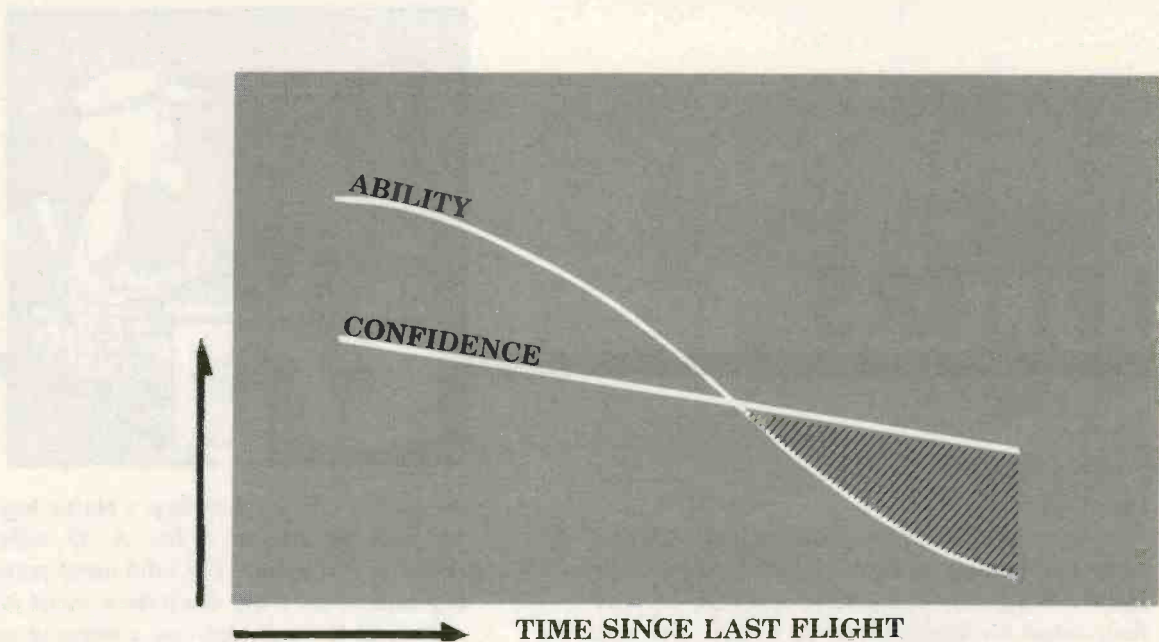

Be prepared

If you commute to a flying station, give the airline hostess a break and use the time to study the Dash One or the master question file. Arrive early and complete egress training, SEPT, tests, FCIF reviews, etc. Finish before you get into a time crunch. Let the flight leader know what your background, recent experience and requirements are; this way you'll avoid being briefed to

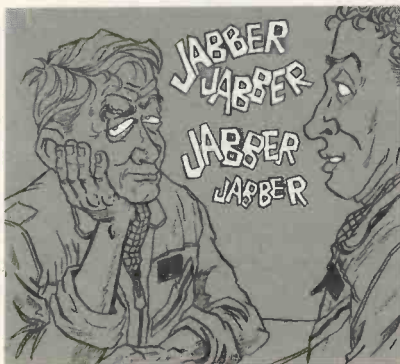

tears on the standards, or, conversely, getting a lot of winks, "standards" and a 50-minute petty break before you step to the aircraft. If you are the leader, get up for the mission

just like you did when you were a squadron pogue.

Mentally rehearse the mission from start to finish, even though you'll be performing tasks that you've done a thousand times. This will eliminate the hesitation that seems to follow a lack of recent experience. You don't need hesitation at the apex of a pop pattern or when closing for a snap shot.

Pay attention

Listen to the briefing. They're especially important when you fly at unfamiliar bases. If you find your mind wandering back to those red-hot suspenses in your in-basket, pinch yourself; this is the *real* air force where aircraft can smack into each other or the ground in a heartbeat. Flying deserves the focus of every brain cell you can muster.

Keep your rituals

Don't break tradition. Wear your lucky G-suit that's never been washed. Take your flashlight that's held together with

electrical tape. On your way around the jet, kick the tires or do a chin-up on the pylon sway brace if that's your normal routine. Flying fighters is a ceremonious process. We have all felt impending doom when things aren't right, when something's been left out of the ritual.

Challenge yourself

Finally, don't lower your professional standards because others expect less of you. Many flyers expect less of you because you're a desk jockey. Surprise them. Strive to be the best at every task—formation, radios, weapons employment, instruments. Take *their* quarter. Make them grudgingly admit you're not a bad aviator for a staff type. If you do screw up, accept criticism and do it better next time. ➤

Maj Keeney is a HQ TAC/Stan Eval F-15 program manager. The 1971 Texas A&M grad has over 13 years of fighter experience in the A-7D and various models of the F-15.

LETTERS



Dear Editor

In your article concerning the handling of the BDU-33 (February, Weapons Words, page 14), you stated "Being heavier, the nose of a BDU-33 falls first—when it's dropped from an aircraft, and when it's accidentally dropped by a weapons handler." Several hundred years ago, Galileo proved that objects of different mass fall at equal rates. The current theory is 32 feet per second per second. Any variance to the theory is in the aerodynamics of the object dropped. This explains why the nose hits the ground first when dropped from an aircraft.

However, Sir, because of the short distance, aerodynamics is not a determining factor when a BDU-33 is accidentally dropped by a weapons handler. I believe that it falls on its nose when accidentally dropped because the weapons handler holds the bomb by the fin.

I've enjoyed reading *TAC Attack* for many years and look forward to many more. Keep up the good work.

SSgt Michael A. Du Bois
127 CAM Sq
Selfridge ANGB, Michigan



Dear Sergeant Du Bois

Nice catch. Thank goodness for Galileo.

ED

Dear Editor

I read with interest the Weapons Words article "Dad Was Wrong" (February 1985, page 15), and I would like to point out the fact that it would be impossible for

the subject OSI agent to drop a plastic bag of bullets and have one detonate or fire. A .45 caliber bullet, as issued to OSI agents, is a solid metal projectile void of any explosives. I will admit those metal projectiles are assembled to a cartridge case containing an explosive primer and propellant. I'm quite sure the bag that fell from the clearing barrel stand contained .45 caliber cartridges. Correct?

Enough nit-picking, let's get down to facts. Each C agent is allocated 25 rounds of .45 caliber ammunition. The fiberboard cartons issued to the OSI offices contain 50 rounds each. The cartridges should not be classified "in storage" when issued to the OSI office, but rather "in use." A greater state of readiness is warranted and, as such, each agent may find it necessary to load on the run. They would lose time if they had to open a box containing 50 cartridges and count out 25. This is the reason they use plastic bags containing 25 cartridges each.

The mishap that occurred with the plastic bag could have happened as well with an open fiberboard carton. Weapons safety personnel can only do so much due to our limited manpower. What ever happened to operator common sense? The addition of a simple shelf to the clearing barrel stand could have prevented this mishap.

James Trepoy, GS-12
Chief, Explosives Safety Branch
HQ USAF Air Defense Weapons Center
Tyndall AFB, Florida

Dear Mr. Trepoy

Congratulations, you got the point—identifying and fixing hazards in the workplace instead of waiting for an accident to highlight them. Wonder if the Lone Ranger's silver bullets were attached to brass cartridges.

ED

TAC TALLY



CLASS A MISHAPS
AIRCREW FATALITIES
TOTAL EJECTIONS
SUCCESSFUL EJECTIONS

TAC		
FEB	THRU FEB	
	1985	1984
2	4	5
1	2	6
1	3	0
1	3	0

ANG		
FEB	THRU FEB	
	1985	1984
1	2	1
0	0	0
1	2	1
1	2	1

AFR		
FEB	THRU FEB	
	1985	1984
0	0	0
0	0	0
0	0	0
0	0	0

TAC'S TOP 5 thru FEB 85

TAC FTR/RECCE		
class A mishap-free months		
31	405 TFW	(F-15) Luke AFB, AZ
25	1 TFW	(F-15) Langley AFB, VA
24	33 TFW	(F-15) Eglin AFB, FL
22	23 TFW	(A-10) England, AFB LA
21	49 TFW	(F-15) Holloman AFB, NM

TAC AIR DEFENSE		
class A mishap-free months		
145	57 FIS	(F-4) Keflavik, Iceland
98	5 FIS	(F-106) Minot AFB, ND
95	48 FIS	(F-15) Langley AFB, VA
54	318 FIS	(F-15) McChord AFB, WA
45	87 FIS	(F-106) KI Sawyer AFB, MI



TAC-GAINED FTR/RECCE		
class A mishap-free months		
154	188 TFG	ANG(F-4) Ft Smith, AR
146	138 TFG	ANG(A-7) Tulsa, OK
145	917 TFG	AFR(A-10) Barksdale AFB, LA
123	114 TFG	ANG(A-7) Sioux Falls, SD
112	183 TFG	ANG(F-4) Springfield, IL

TAC-GAINED AIR DEFENSE		
class A mishap-free months		
128	177 FIG	ANG(F-106) Atlantic City, NJ
94	125 FIG	ANG(F-106) Jacksonville, FL
77	119 FIG	ANG(F-4) Fargo, ND
61	107 FIG	ANG(F-4) Niagara Falls, NY
52	147 FIG	ANG(F-4) Ellington AFB, TX

TAC/GAINED Other Units		
class A mishap-free months		
187	182 TASG	ANG(OA-37) Peoria, IL
171	110 TASG	ANG(OA-37) Battle Creek, MI
167	USAFTAWC	(many fighters) Eglin AFB, FL
159	84 FITS	(T-33) Castle AFB, CA
101	552 AWACD	(E-3) Tinker AFB, OK

CLASS A MISHAP COMPARISON RATE

(BASED ON ACCIDENTS PER 100,000 HOURS FLYING TIME)

	1985	1984										
TAC	3.2	3.4										
	3.4	4.3										
ANG	4.8	4.8										
	0.0	2.3										
AFR	0.0	0.0										
	0.0	0.0										

JAN FEB MAR APR MAY JUN JUL AUG SEP OCT NOV DEC

FLEAGLE

WHATTA MESS.



SURE WILL BE NICE T'GET INTO SUMPIN' DRY AND A FIST FULL OF HOT COCO.



OK, LETS GET ALL LINED UP HERE AN' DO THIS RIGHT TH' FIRST TIME.



TOUCH DOWN... DRIFTING A LITTLE OFF CENTER... NO SWEAT, I CAN HANDLE IT.



DON'T SEEM T'BE SLOWIN' DOWN NONE... WHY'S ALL THAT WATER AN' MESS SPRAYIN' UP 'TWEEN MY TOES? I'M RUNNIN' OUTTA RUNWAY !!



MOTHER NATURE SCORES ANOTHER ONE. WITH TH'HELP OF PAINT AN' RUBBER DROPPINGS NEAR TH'END OF TH'RUNWAY.

